

AGENDA ITEM 7

APPENDIX I

2022/0023/DET

PLANS

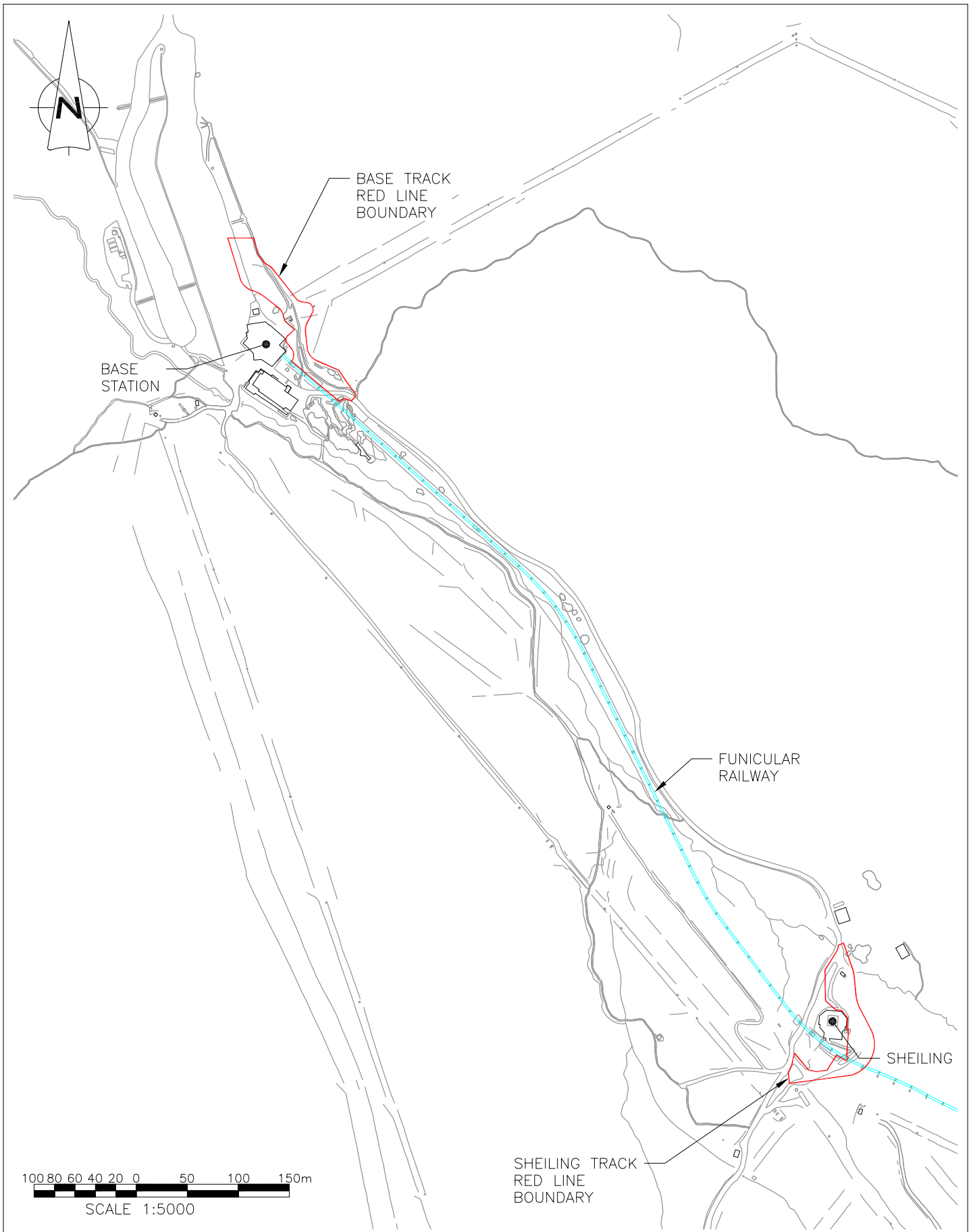

Wallace Stone

Consulting Civil Engineers

GLASGOW
0141 554 8233
glasgow@wallacestone.co.uk

DINGWALL
01349 866775
dingwall@wallacestone.co.uk

HEBRIDES
01851 612454
hebrides@wallacestone.co.uk

CAIRNGORM MOUNTAIN LTD. CAIRNGORM HILL TRACK DESIGN LOCATION PLAN

DRAWING NO. 2317-110

DRAWN: ADS

DATE: 05.01.22

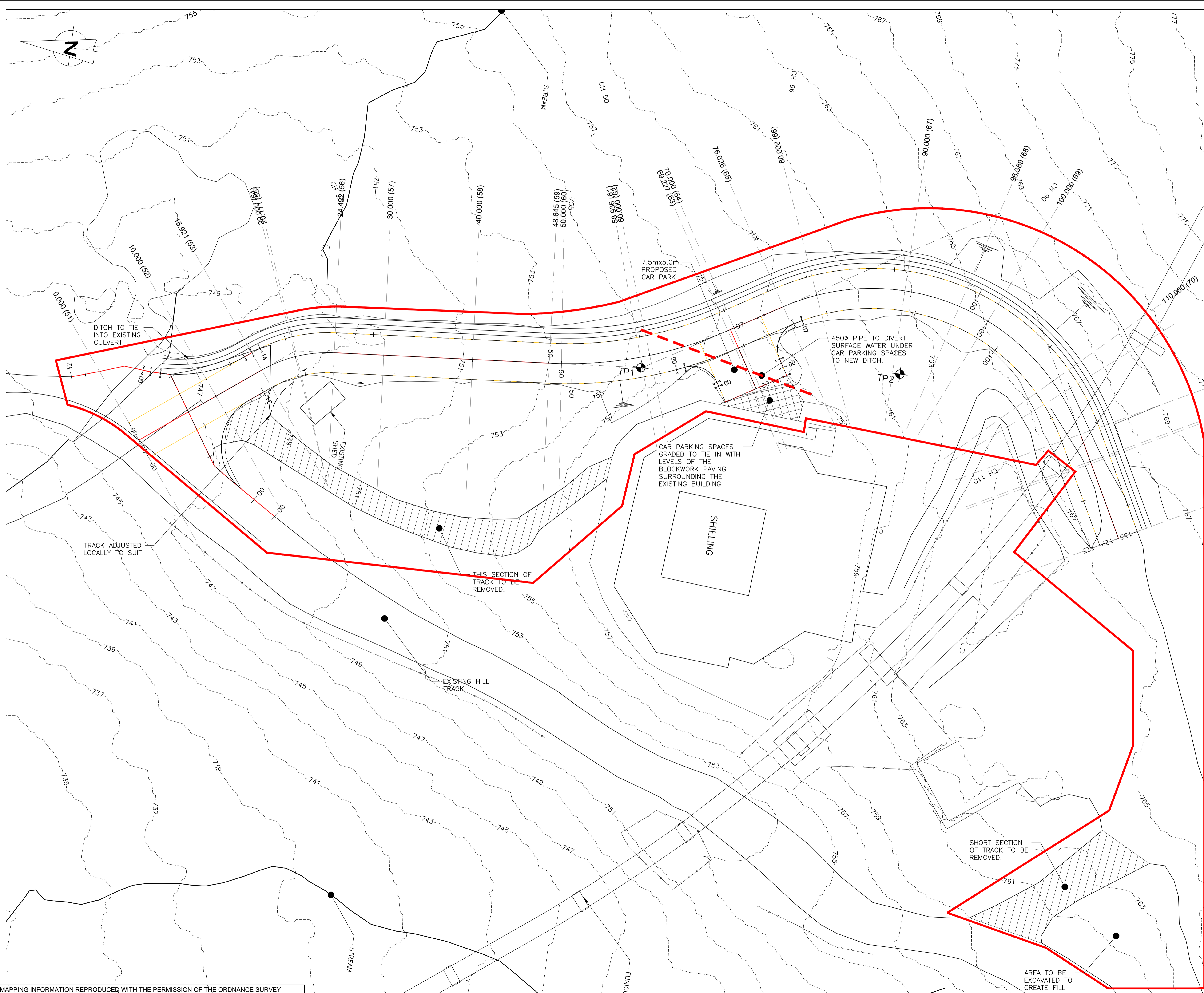

- GENERAL NOTES**
1. ALL DIMENSIONS ARE IN METRES UNLESS NOTED OTHERWISE.
 2. ALL LEVELS ARE IN METRES AND RELATE TO ORDNANCE DATUM.
 3. LAYOUT BASED ON SURVEY BY PROPERTY AND LAND SURVEYS 2019.
 4. FOR TRIAL PIT RESULTS REFER TO 2317-DOC 01 - TRIAL PIT LOG.

LEGEND:

TP1 - TRIAL PITS COMPLETED MAY 2021.

[Red Outline] - WORKS BOUNDARY PLANNING CONSENTS = 3735m²

REV	DATE	DETAILS	DRAWN	CHK'D	APP'D
D	12.11.21	PLANNING BOUNDARY ADDED	PM	TR	TR
C	04.11.21	CULVERT ROUTE AMENDED. HATCHING ADDED TO CAR PARK	ADS	NG	NG
B	03.11.21	EMBANKMENT START POINT AMENDED	ADS	NG	NG
A	21.10.21	TRACK ALIGNMENT AMENDED	ADS	NG	TR

AMENDMENTS

CLIENT: CAIRNGORM MOUNTAIN (SCOTLAND) LTD

PROJECT: CAIRNGORM HILL TRACK DESIGN

Wallace Stone
Consulting Civil Engineers

GLASGOW 0141 554 8233 glosgow@wallacestone.co.uk
DINGWALL 01349 866775 dingwall@wallacestone.co.uk
HEBRIDES 01851 612454 hebrides@wallacestone.co.uk

DRAWING TITLE: PROPOSED SHIELING ACCESS TRACK LOCATION

DRAWN: PM	CHECKED: NIG	APPROVED: TR
DATE: SEPT 21	DATE: 14.09.21	DATE: 14.09.21

SCALE (A1): 1:200	STAGE: CONSENTS
REVISION: A B C D	

PROJECT No. 2317	DRAWING No. 101
------------------	-----------------

MAPPING INFORMATION REPRODUCED WITH THE PERMISSION OF THE ORDNANCE SURVEY
© CROWN COPYRIGHT ALL RIGHTS RESERVED. LICENCE NO. AL100002578.

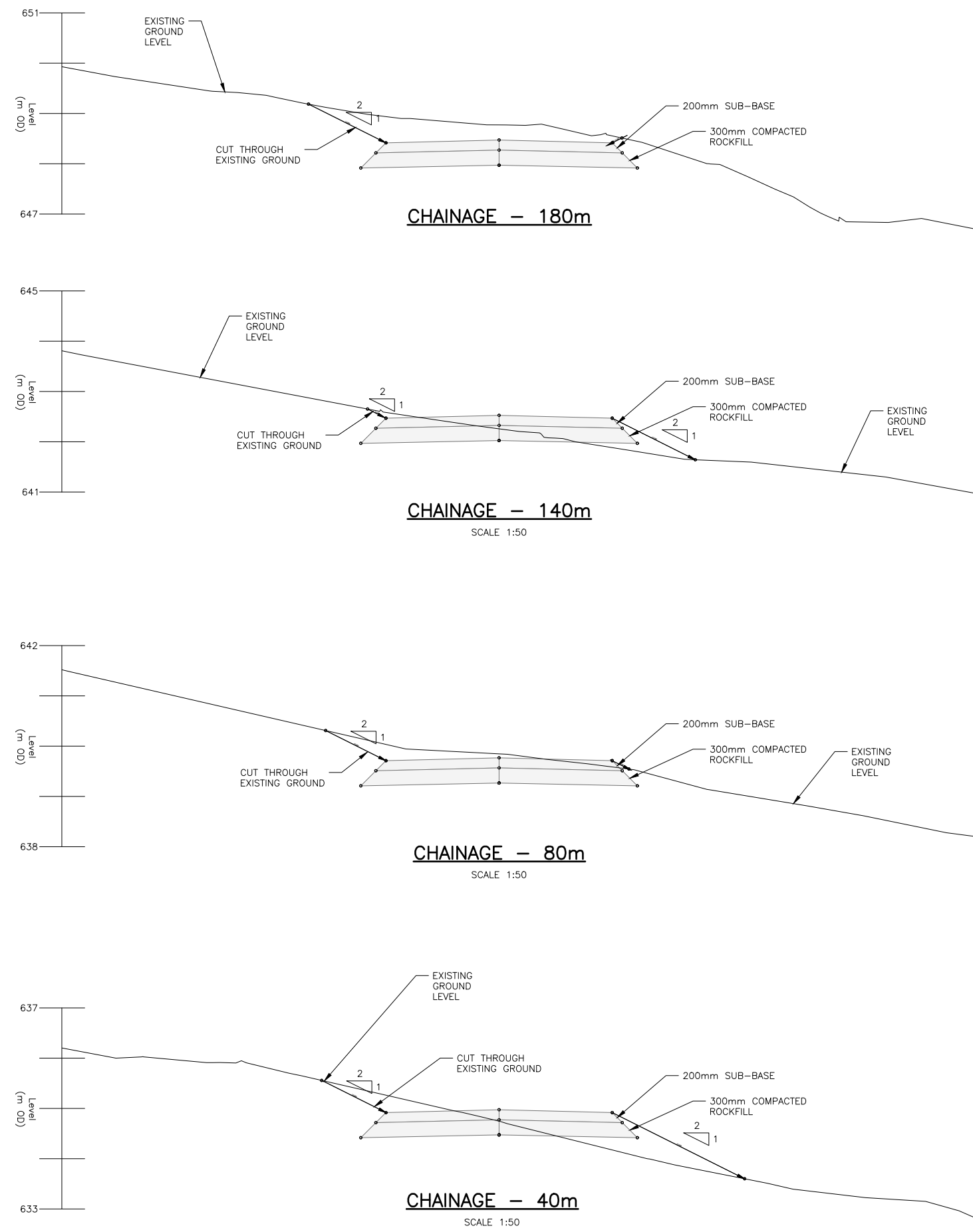

GENERAL NOTES

1. ALL DIMENSIONS ARE IN METRES UNLESS NOTED OTHERWISE.
2. ALL LEVELS ARE IN METRES AND RELATE TO ORDNANCE DATUM.
3. FOR CHAINAGE LOCATIONS SEE DRAWING 2317-105

REV	DATE	DETAILS	DRAWN	CHK'D	APP'D
A	03.11.21	EDGE OF EMBANKMENT START POINT AMENDED.	ADS	NG	NG

AMENDMENTS

CLIENT
CAIRNGORM MOUNTAIN (SCOTLAND) LTD

PROJECT
CAIRNGORM HILL TRACK DESIGN

Wallace Stone
Consulting Civil Engineers

GLASGOW 0141 554 8233 glasgow@wallacestone.co.uk
DINGWALL 01349 866775 dingwall@wallacestone.co.uk
HEBRIDES 01851 612454 hebrides@wallacestone.co.uk

DRAWING TITLE
PROPOSED BASE TRACK CROSS SECTIONS

DRAWN AS	CHECKED NG	APPROVED TR
DATE OCT 2021	DATE OCT 2021	DATE OCT 2021

SCALE (A1) 1:50 STAGE **CONSENTS**

REVISION	A								
----------	---	--	--	--	--	--	--	--	--

PROJECT No.	DRAWING No.
2317	107

GENERAL NOTES

1. ALL DIMENSIONS ARE IN METRES UNLESS NOTED OTHERWISE.
2. ALL LEVELS ARE IN METRES AND RELATE TO ORDNANCE DATUM.
3. MAXIMUM TRACK GRADIENT = 22.42%

KEY

- EXISTING GROUND PROFILE
- PROPOSED TRACK PROFILE

BASE STATION TRACK ALIGNMENT
SCALE: HORIZONTAL 1:50, VERTICAL 1:50.

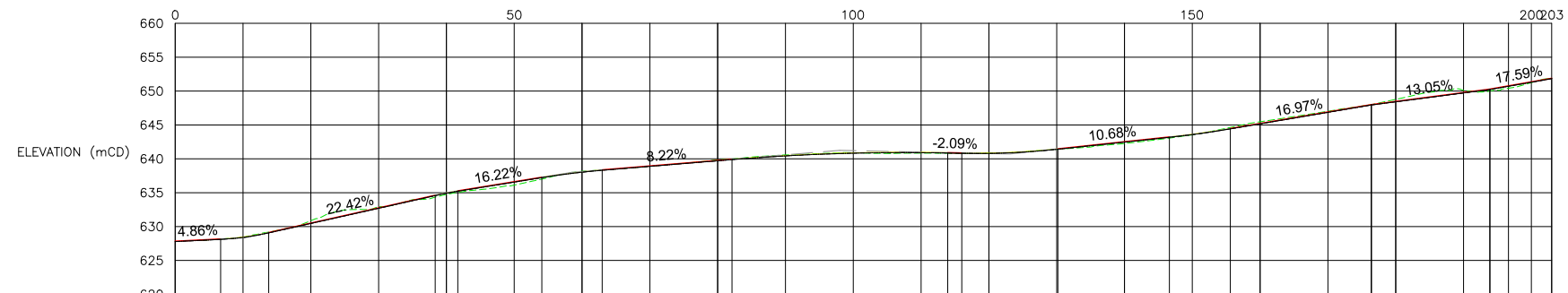

Chainage	Existing Levels	Proposed Levels
0.000		627.840
10.000	628.410	628.457
20.000	630.866	630.516
30.000	632.938	632.758
40.000	634.746	
50.000	636.127	636.622
60.000	638.170	638.084
70.000	638.866	638.945
80.000	639.846	639.766
90.000	640.574	640.487
100.000	640.901	640.890
110.000	640.838	640.969
120.000	640.847	640.856
130.000	641.394	641.456
140.000	642.258	642.525
150.000	643.535	643.633
160.000	645.469	645.219
170.000	647.025	646.916
180.000	648.773	648.472
190.000	650.093	649.777
200.000	651.247	651.360
202.03	651.886	651.886

REV	DATE	DETAILS	DRAWN	CHK'D	APP'D
A	03.11.21	TOP END OF ALIGNMENT AMENDED TO EASE TIE IN	ADS	NG	NG

AMENDMENTS

CLIENT
CAIRNGORM MOUNTAIN (SCOTLAND) LTD

PROJECT
CAIRNGORM HILL TRACK DESIGN

Wallace Stone
Consulting Civil Engineers

GLASGOW: 0141 554 8233, glasgow@wallacestone.co.uk
DINGWALL: 01349 866775, dingwall@wallacestone.co.uk

HEBRIDES: 01851 612454, hebrides@wallacestone.co.uk

DRAWING TITLE
PROPOSED BASE TRACK LONG SECTION

DRAWN	CHECKED	APPROVED
AS	NG	TR
DATE	DATE	DATE
OCT 2021	OCT 2021	OCT 2021

SCALE (A1) 1:50 STAGE
CONSENTS

REVISION	A								
PROJECT No.	2317				DRAWING No.	106			

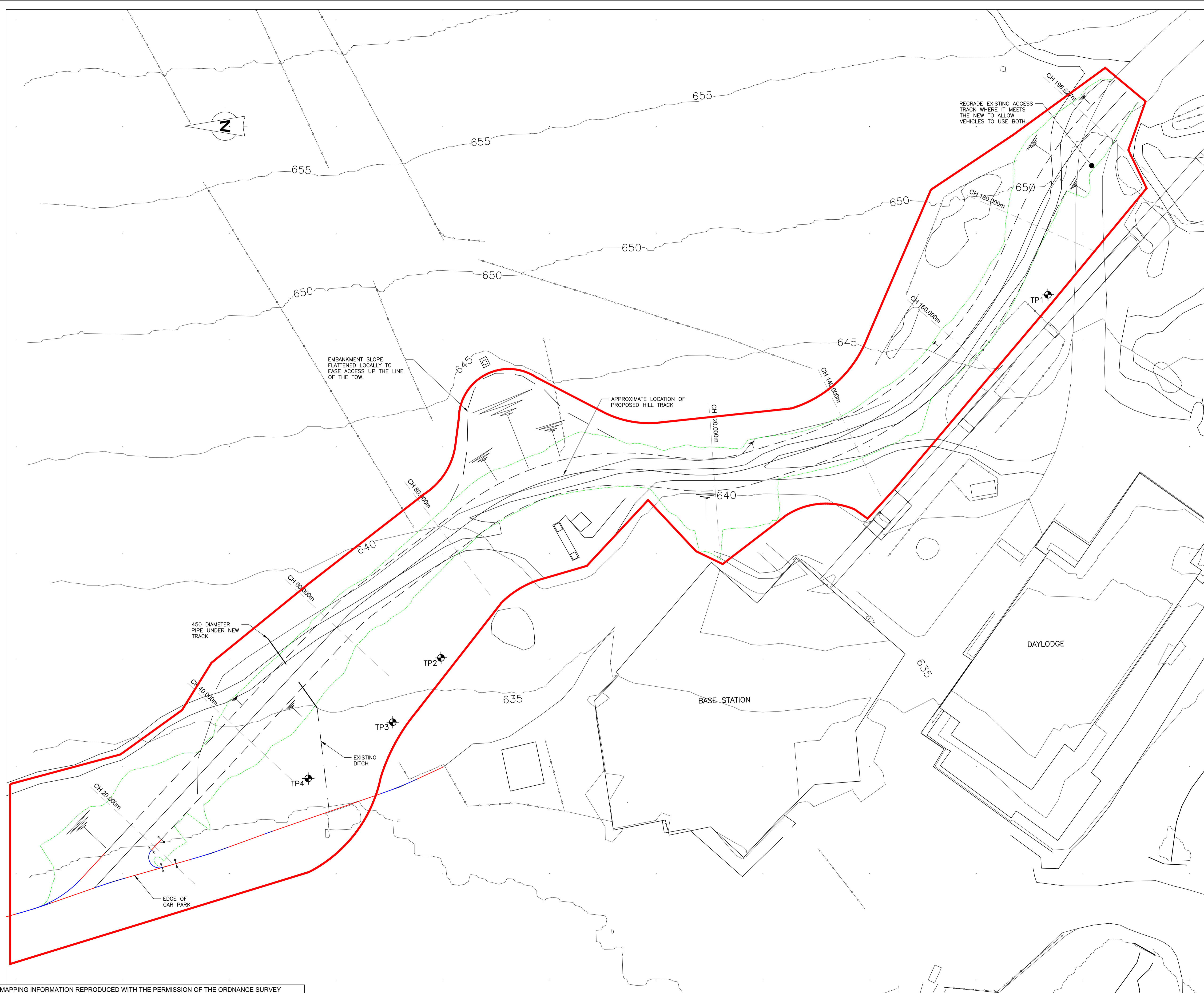

GENERAL NOTES

1. ALL DIMENSIONS ARE IN METRES UNLESS NOTED OTHERWISE.
2. ALL LEVELS ARE IN METRES AND RELATE TO ORDNANCE DATUM.
3. LAYOUT BASED ON SURVEY BY PROPERTY AND LAND SURVEYS 2019.
4. LOCATION OF PROPOSED ACCESS TRACK IS APPROXIMATE UNTIL COMPLETION OF TRACK DESIGN.
5. FOR TRIAL PIT RESULTS REFER TO 2317-DOC 01 - TRIAL PIT LOG.

LEGEND:

- TP1 - TRIAL PITS COMPLETED MAY 2021.
- WORKS BOUNDARY PLANNING CONSENTS = 4300m²

REV	DATE	DETAILS	DRAWN	CHK'D	APP'D
B	12.11.21	PLANNING BOUNDARY ADDED	PM	TR	TR
A	03.11.21	NOTES ADDED, START OF EMBANKMENT SLOPE MOVED	ADS	NG	NG

AMENDMENTS

CLIENT CAIRNGORM MOUNTAIN (SCOTLAND) LTD

PROJECT CAIRNGORM HILL TRACK DESIGN

Wallace Stone
Consulting Civil Engineers

GLASGOW 0141 554 8233 glosgow@wallacestone.co.uk
DINGWALL 01349 866775 dingwall@wallacestone.co.uk
HEBRIDES 01851 612454 hebrides@wallacestone.co.uk

DRAWING TITLE

PROPOSED BASE TRACK PLAN

DRAWN	CHECKED	APPROVED
ADS	NG	TR
DATE	DATE	DATE
OCT 2021	OCT 2021	OCT 2021
SCALE (A1)	1:250	STAGE
CONSENTS		
REVISION	A B	

PROJECT No.	DRAWING No.
2317	105

MAPPING INFORMATION REPRODUCED WITH THE PERMISSION OF THE ORDNANCE SURVEY ©CROWN COPYRIGHT ALL RIGHTS RESERVED. LICENCE NO. AL10002578.

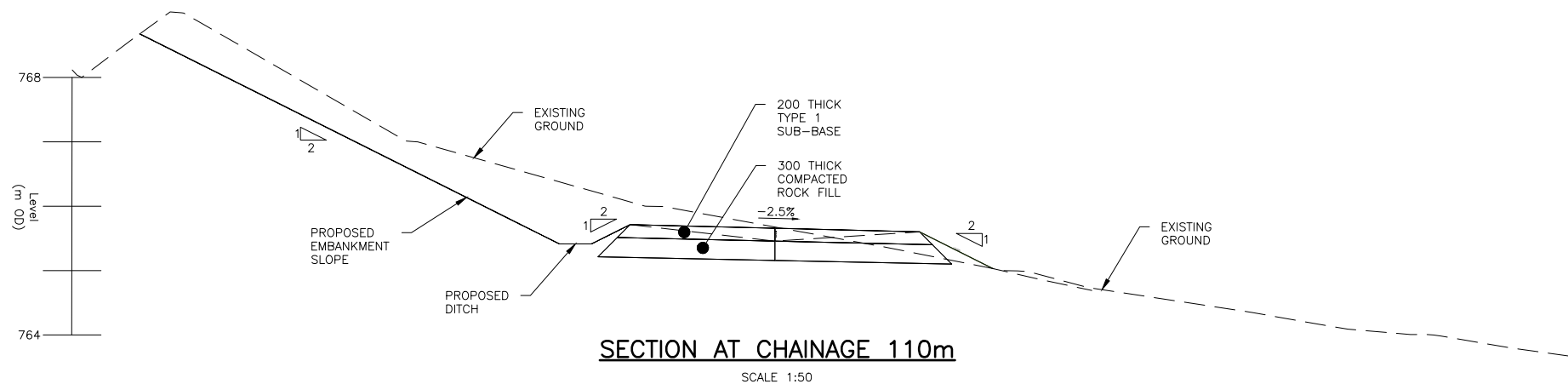

SECTION AT CHAINAGE 110m

SCALE 1:50

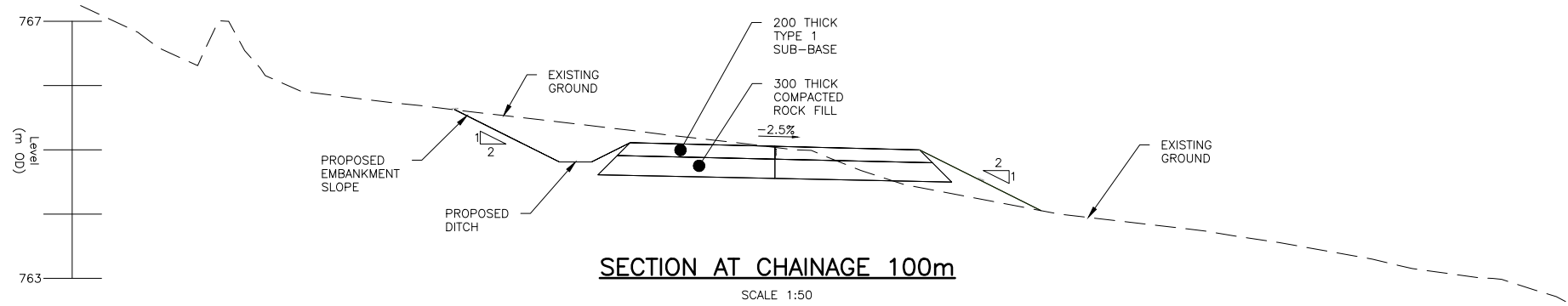

SECTION AT CHAINAGE 100m

SCALE 1:50

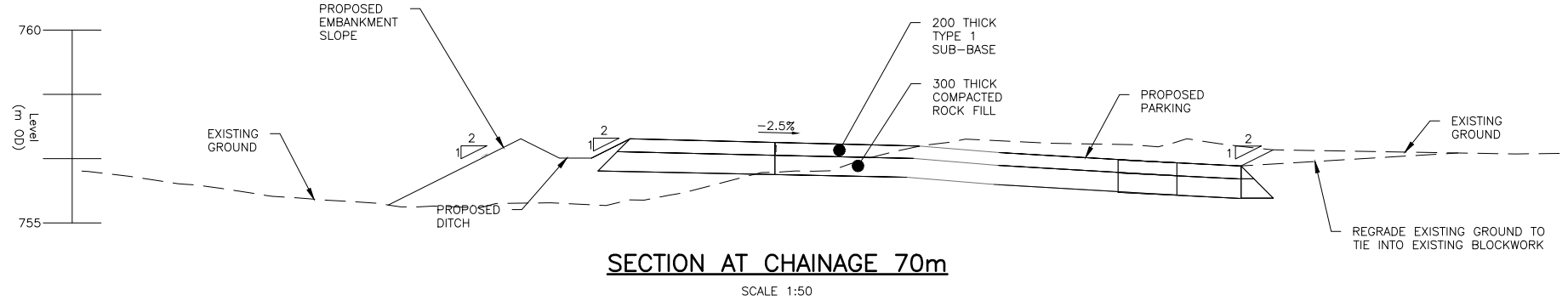

SECTION AT CHAINAGE 70m

SCALE 1:50

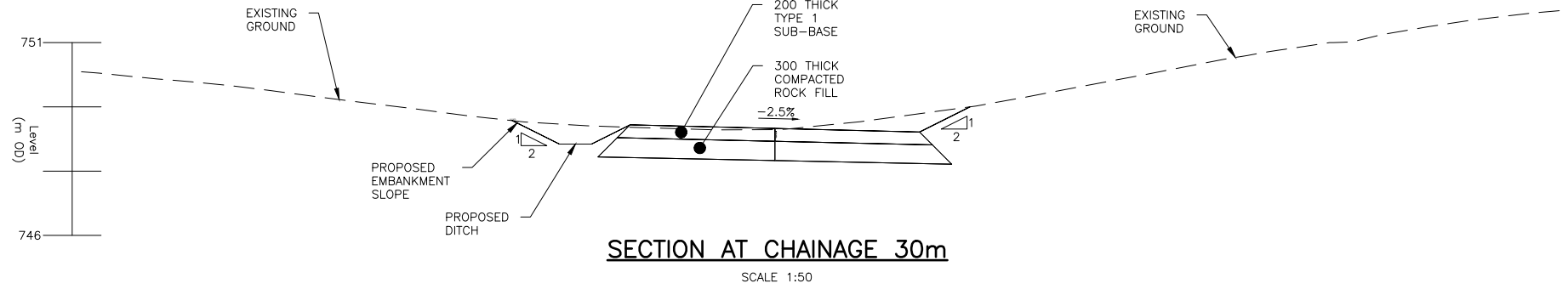

SECTION AT CHAINAGE 30m

SCALE 1:50

GENERAL NOTES

1. ALL DIMENSIONS ARE IN METRES UNLESS NOTED OTHERWISE.
2. ALL LEVELS ARE IN METRES AND RELATE TO ORDNANCE DATUM.
3. FOR CHAINAGE LOCATIONS SEE DRAWING 2317-101

REV	DATE	DETAILS	DRAWN	CHK'D	APP'D
B	03.11.21	NOTE ADDED TO REAR OF CAR PARKING SPACES	ADS	NG	NG
A	21.10.21	TRACK ALIGNMENT AMENDED	ADS	NG	TR

AMENDMENTS

CLIENT **CAIRNGORM MOUNTAIN (SCOTLAND) LTD**

PROJECT **CAIRNGORM HILL TRACK DESIGN**

Wallace Stone
Consulting Civil Engineers

GLASGOW 0141 554 8233 glasgow@wallacestone.co.uk
DINGWALL 01349 866775 dingwall@wallacestone.co.uk
HEBRIDES 01851 612454 hebrides@wallacestone.co.uk

DRAWING TITLE

PROPOSED SHIELING ACCESS TRACK CROSS SECTIONS

DRAWN PM	CHECKED NIG	APPROVED TR
DATE SEPT 21	DATE 14.09.21	DATE 14.09.21

SCALE (A1) 1:50 STAGE **CONSENTS**

REVISION	A	B							
----------	---	---	--	--	--	--	--	--	--

PROJECT No.	DRAWING No.
2317	103

SHIELING ACCESS TRACK LONGSECTION
SCALE: HORIZONTAL 1:200, VERTICAL 1:200.

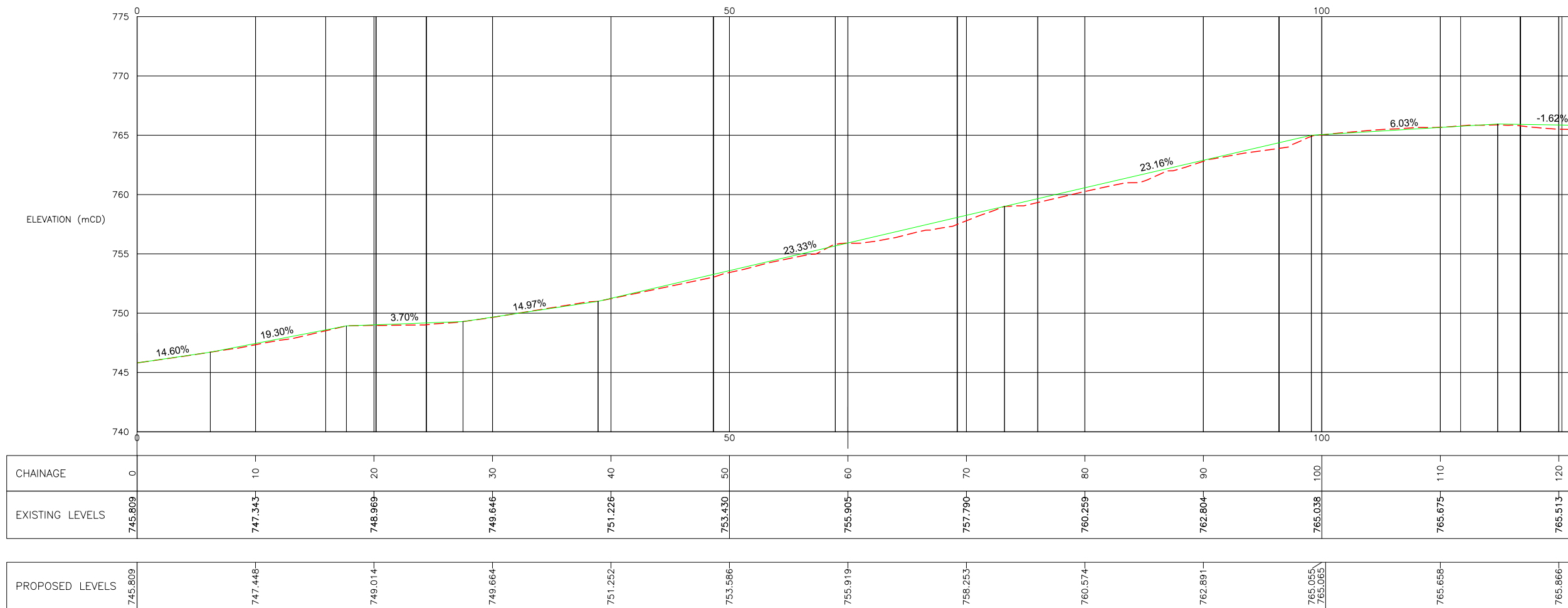

GENERAL NOTES

1. ALL DIMENSIONS ARE IN METRES UNLESS NOTED OTHERWISE.
2. ALL LEVELS ARE IN METRES AND RELATE TO ORDNANCE DATUM.
3. MAXIMUM TRACK GRADIENT = 23.33%

LEGEND:

- EXISTING GROUND PROFILE
- PROPOSED TRACK PROFILE
- 18.31% PROPOSED TRACK GRADIENT

REV	DATE	DETAILS	DRAWN	CHK'D	APP'D
A	21.10.21	TRACK ALIGNMENT AMENDED	ADS	NG	NG

AMENDMENTS

CLIENT
CAIRNGORM MOUNTAIN (SCOTLAND) LTD

PROJECT
CAIRNGORM HILL TRACK DESIGN

Wallace Stone
Consulting Civil Engineers

GLASGOW 0141 554 8233 glasgow@wallacestone.co.uk
DINGWALL 01349 866775 dingwall@wallacestone.co.uk

HEBRIDES 01851 612454 hebrides@wallacestone.co.uk

DRAWING TITLE
PROPOSED SHIELING ACCESS TRACK LONG SECTION

DRAWN	CHECKED	APPROVED
PM	NIG	TR
DATE	DATE	DATE
SEPT 21	14.09.21	14.09.21

SCALE (A1) 1:200 STAGE **CONSENTS**

REVISION	A								
----------	---	--	--	--	--	--	--	--	--

PROJECT No.	DRAWING No.
2317	102

MAPPING INFORMATION REPRODUCED WITH THE PERMISSION OF THE ORDNANCE SURVEY
©CROWN COPYRIGHT ALL RIGHTS RESERVED. LICENCE NO. AL10002578.



Existing aerial view

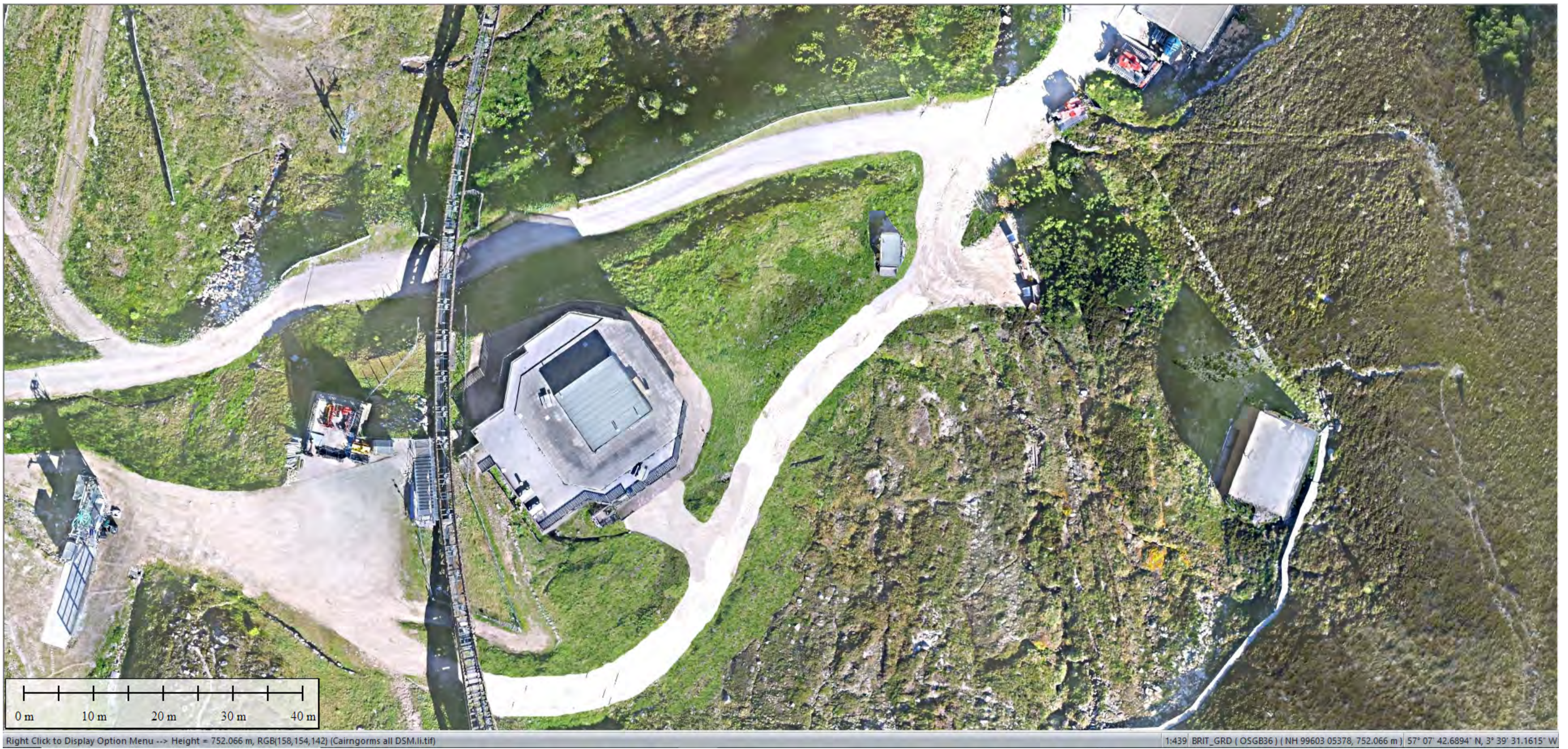

Aerial view showing proposed Shieling track.

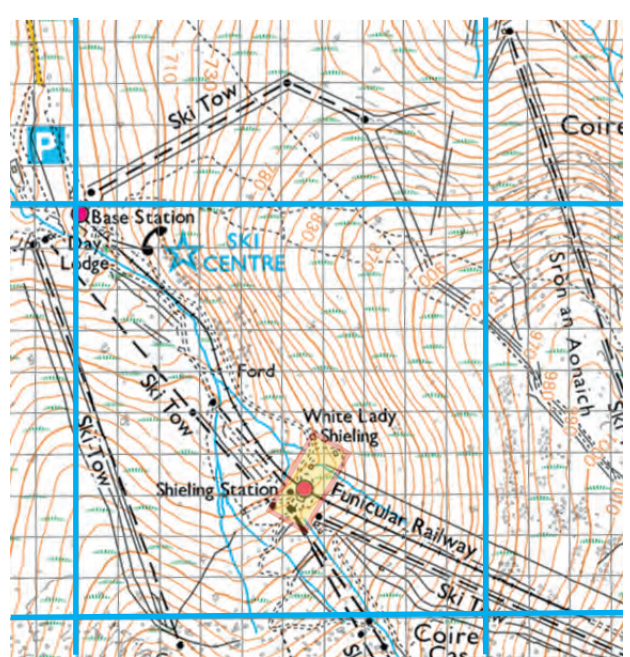

Scale 1 to 500 when viewed as a PDF at 100%
 or printed at 100%.

Start of proposed track
 NH 99567 05388
 747 metres ASL

End of proposed track
 NH 99565 05283
 765 metres ASL

Drawn by J.C.
 01/03/22.



Daylodge Track
 Cairngorm Ski Area, PH22 1RB
 Proposed location from Coire Cas Car park to lock block crossing at mountain garden.

CMSL Document Title: Viewpoint Daylodge track at Daylodge Poma drive station.



Existing View South East



Visualisation View South East

Notes:
 View point location chosen by CNPA Planning mid way along track
 at Daylodge Poma ski lift.



Existing View North East



Visualisation View North East

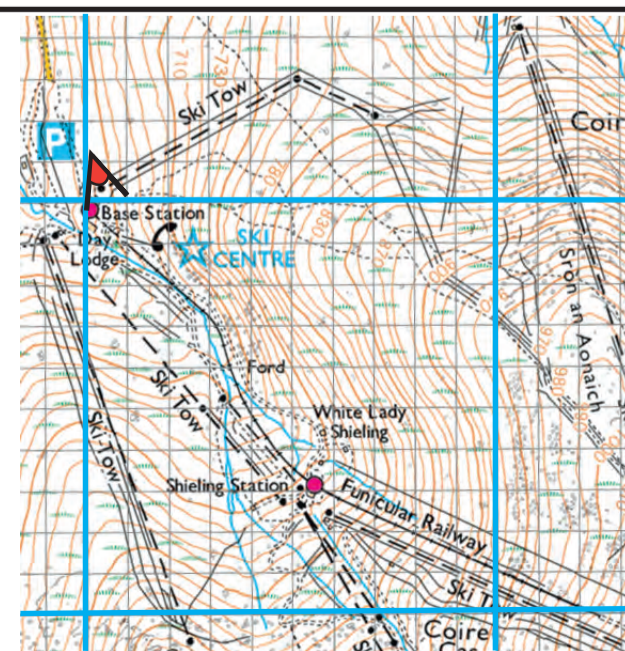

Viewpoint O.S. reference: NH99029 06003
 Viewpoint elevation: 640 Metres
 Direction of View: 130 ° South East
 Enlargement factor: 0
 Horizontal field of view: 30 °
 Vertical Field of view: 6 °

Camera height : 1.5 metre AGL
 Date: 24/09/21
 Time: 10:43am
 Image: N.G.
 Drawn by J.C.
 02/03/22

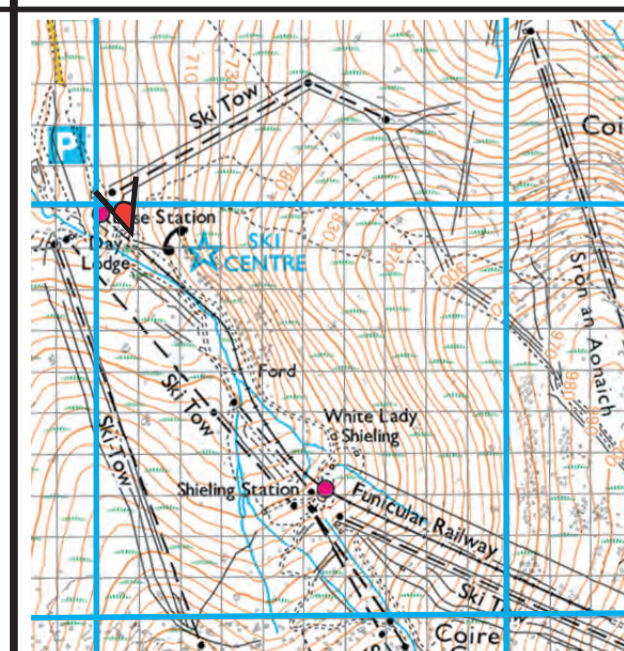

Viewpoint O.S. reference: NH99034 06003
 Viewpoint elevation: 640 Metres
 Direction of View: 49 ° North East
 Enlargement factor: 0
 Horizontal field of view: 109°
 Vertical Field of view: 9 °

Camera height : 1.5 metre AGL
 Date: 02/03/22
 Time: 09:49am
 Image: N.G.
 Drawn by J.C.
 02/03/22



Paper Size: A2
 Correct print size: Height 750mm Width 415mm

Daylodge Track
 Cairngorm Ski Area, PH22 1RB
 Proposed location from Coire Cas Car park to lock block crossing at mountain garden.

CMSL Document Title: Viewpoint A - Daylodge track at Car Park entry.
 Viewpoint B - Daylodge track at upper end.

Viewpoint A



Existing View South East



Visualisation View South East

Notes:
 View point location chosen by CNPA Planning at Car Park



Viewpoint O.S. reference: NH98974 06081
 Viewpoint elevation: 628 Metres
 Direction of View: 138 ° South East
 Enlargement factor: 0
 Horizontal field of view: 48 °
 Vertical Field of view: 10.5 °

Camera height : 1.5 metre AGL
 Date: 24/09/21
 Time:10:43am
 Image: N.G.
 Drawn by J.C.
 02/03/22

Viewpoint B



Existing View North west



Visualisation View North west



Viewpoint O.S. reference: NH99090 05937
 Viewpoint elevation: 652 Metres
 Direction of View: 338° North
 Enlargement factor: 0
 Horizontal field of view:56 °
 Vertical Field of view: 2 °

Camera height : 1.5 metre AGL
 Date: 09/07/21
 Time:11:42am
 Image: N.G.
 Drawn by J.C.
 02/03/22



Paper Size: A2
 Correct print size: Hieght 750mm Width 415mm



Existing aerial view



Aerial view showing proposed daylodge track.

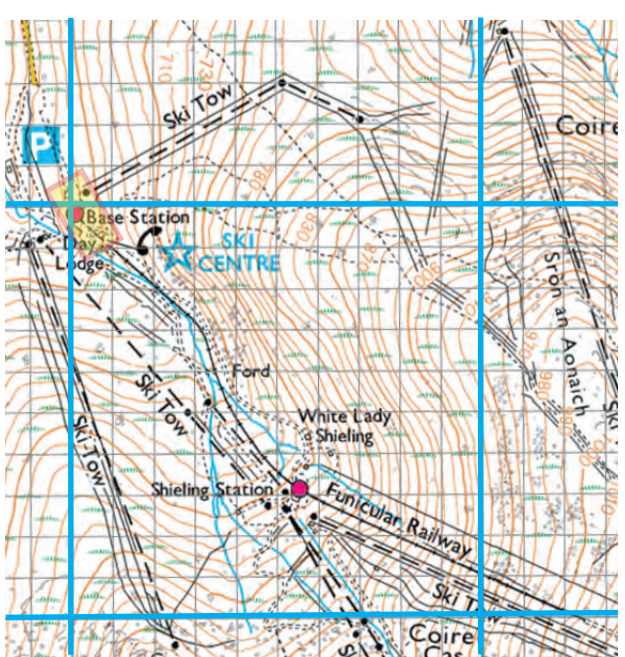

Scale 1 to 500 when viewed as a PDF at 100%
 or printed at 100%.

Start of proposed track
 NH 98977 06082
 628.5 metres ASL

End of proposed track
 NH 99088 05939
 652 metres ASL

Drawn by J.C.
 01/03/22.



Daylodge Track
 Cairngorm Ski Area, PH22 1RB
 Proposed location from Shieling building lock block paving looking from Garage to Mid Station.

CMSL Document Title: Viewpoint from the Shieling Building showing full length of proposed Shieling track.



Existing temporary track view



Visualisation of proposed track.



Notes:
 The proposed track follows the existing temporary track for the lower half.

Viewpoint O.S. reference: NH99567 05341
 Viewpoint elevation: 758.5 Metres
 Direction of View: 167° South
 Distance to road: 12 Metres
 Enlargement factor: 0
 Horizontal field of view: 183°
 Vertical Field of view: 13.5°
 Paper Size: A2
 Correct print size: Hieght 750mm Width 415mm

Camera height : 1.5 metre AGL
 Date: 15/09/2021
 Time:14:23.
 Image: J.C.

Drawn by J.C.
 01/03/22.

